

PRODUCT NUMBER	QUANTITY PER REEL	PACKAGING
73348-Y01(LF)	15000	CARDBOARD REEL

WHEN NEEDED, SUFFIX LETTER "LF" INDICATES THE PRODUCT IS RoHS COMPATIBLE, SEE NOTE

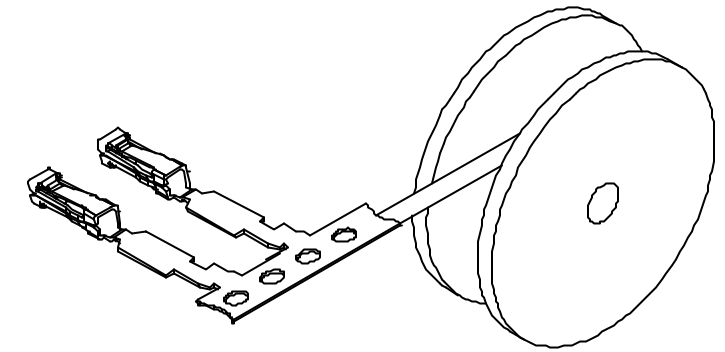
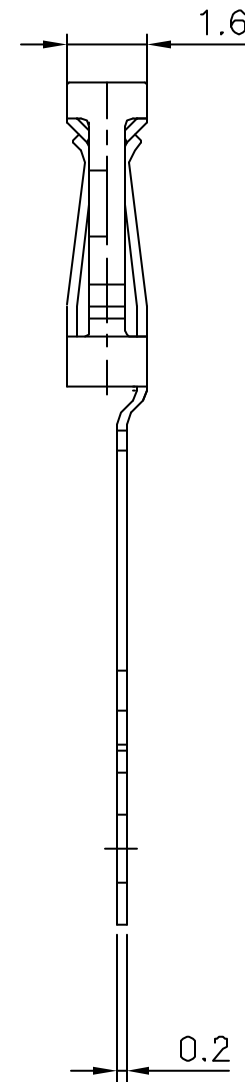
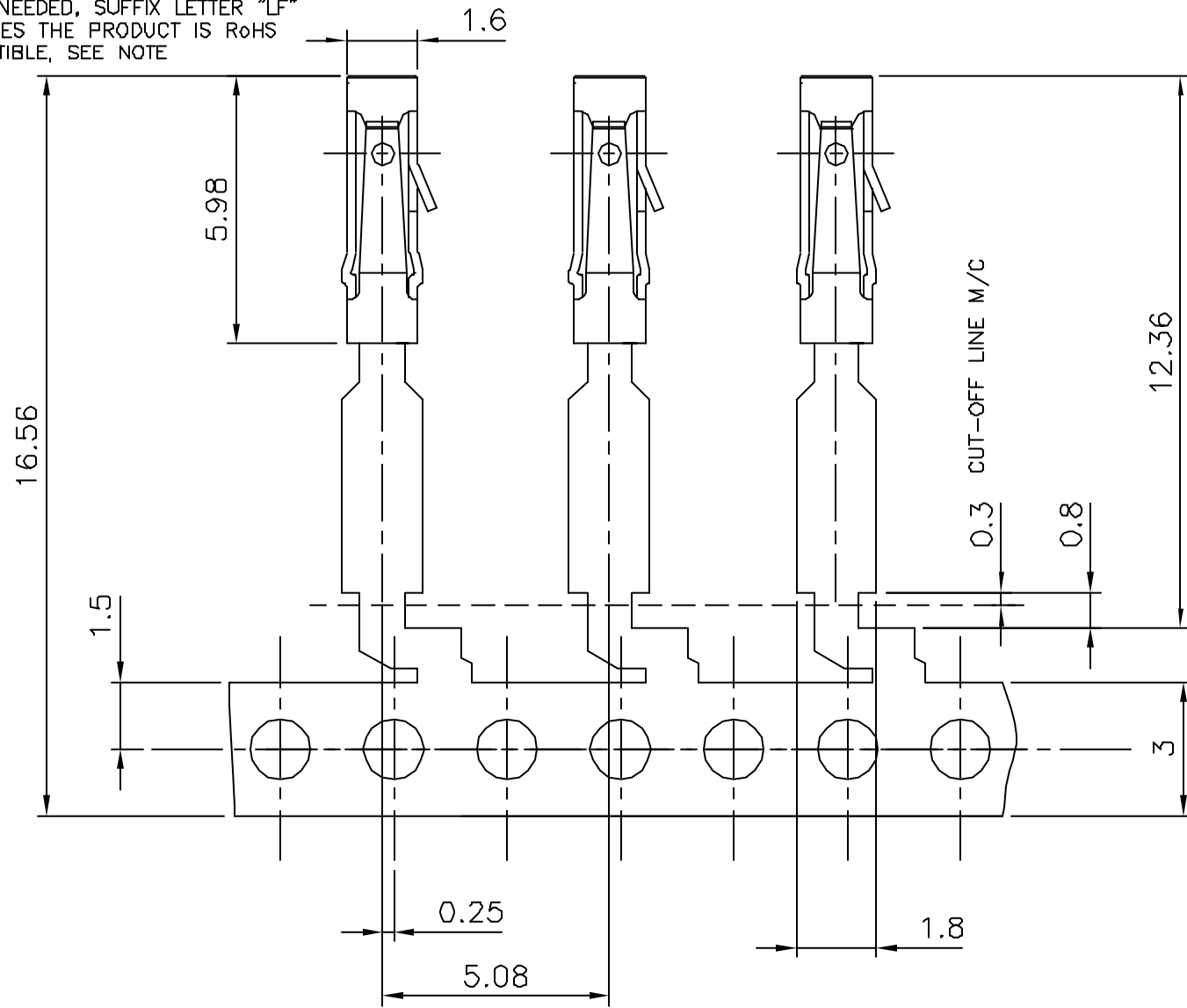

REELING AFTER STAMPING

NOTE:

MATERIAL: PHOSPHOR BRONZE, EXTRA HARD  
RoHS COMPATIBLE PRODUCT SPECIFICATIONS

- a - PLATING:
- "LF" MEANS THE PRODUCT IS LEAD-FREE, 2µm MINIMUM MATTE TIN OVER 1.27µm MINIMUM NICKEL UNDERPLATE.
- b - LABELING:
- MEETS PACKAGING SPECS AS PER GS-14-920
- c - LEGAL STATEMENT: SEE GS-22-008

73348-3XXLF	0.76µm GOLD	Sn	0.3N MIN 0.6N MAX
73348-4XXLF	5µm Sn	Sn	0.3N MIN 0.6N MAX
73348-3XX	0.76µm GOLD	SnPb	0.3N MIN 0.6N MAX
73348-4XX	5µm SnPb	SnPb	0.3N MIN 0.6N MAX
PLATING CODE	CONTACT AREA	SOLDER TAIL	WITHDRAWAL FORCE USING SQUARE PIN 0.61
	PLATING THICKNESS OVER 1.27µm Ni		

mat'l. code		surface	tolerance	projection	product family
SEE NOTES		ISO 1302	ISO 416 ISO 1101	mm	DUFLEX
Ltr	ecm no	dr	date	tolerances unless otherwise specified	title
D	FD4-0374	DLE	D4.11.18	angles	DUFLEX TERM.
E	FO8-D203	DLE	D6.06.20	Linear	WITHOUT IDC
F	F07-027	LMU	D7.12.08	±2°	scale 10:1
		dr	D LEGRAND	0708.06.20	dwg no
		enrg	P NIZZI	06.06.20	sheet 1 of 1
		chr	P NIZZI	06.06.20	size
		appd	P NZ	06.06.20	A3
		FCJ			type
					CUSTOMER
sheet index	revision sheet				



Copyright FCJ